

## INVESTIGATION OF CENTRIFUGAL IMPACT MILLING OF MATERIALS

A. É. Levdanskii

UDC 621.926.4

*Methods of decreasing the energy expended for milling of materials and new designs of mills in which these methods can be realized are proposed. Results of experimental investigations of the processes of milling and classification of particles in the mills proposed are presented.*

The power-intensive process of milling of materials is widely used in various industries. Therefore, the search for the methods of decreasing the energy expended for milling is a major preoccupation of many researchers. In [1–3], it is proposed:

- (a) to mill materials by impact;
- (b) to continuously remove the milled material from the working chamber of a mill to prevent its accumulation in this zone;
- (c) to classify the milled material removed from the milling zone for the purpose of separation of large particles and their recycling to the mill for repeated milling.

These requirements are most likely to be realized in centrifugal impact mills with flow-through classification of particles. More than ten designs of such mills have been developed at the invention level by the author of this work together with other researchers. In the present work, we propose recommendations on the use of three of them [4–6], which have found the most intensive application in industry. The designs of these mills are presented in Fig. 1.

The mills proposed comprise a vertical cylindrical body 1 with plane bottom 2 and separable cover 3. Working disk 4 with blades 5 rotates inside body 1. In the first two variants of the mills (Fig. 1a and b), the plate is clamped on the shaft of electric motor 6. In the third variant, two disks 4 with blades 5 are installed in tandem on shaft 7 positioned at the center of body 1. These disks are driven by electric motor 6 through V-belt transmission 8.

In these mills, reflecting rods 10 are installed along a ring at a small distance from the trailing edges of blades 5. In all the variants, a material is milled by impact. The initial material is delivered through branch pipe 9 to the center of the mill, then it is transported by the air flow to blades 5 and is accelerated to high velocities in the process of movement along the blades. Particles of the material break away from blades 5 and strike against reflecting rods 10, where they are milled by impact. It should be noted that in all the mills, the movement of a continuous medium is analogous to that in centrifugal fans, which makes it possible to use an air flow for transport of the milled material.

The mills proposed differ in design, and these differences are as follows. In mill *a*, reflecting rods 10 of rectangular cross section are installed with a clearance between them. Here, after the material milled strikes against the rods, its particles acted upon by the centrifugal force and the air flow pass through the slots and enter the air flowing in the clearance between the rod and the body of the mill, which moves them through outlet tangential branch pipe 11 to a cyclone and a filter for separation. Because of the vortex motion of the air in the chamber and the oblique impact of the material upon the rods, the milled particles fall on the slots at an angle. Consequently, only those particles whose sizes are much smaller than the size of the slots between the rods can pass through them, which excludes their blockage. The calculations and experimental investigations have shown that the sizes of the particles that passed through the branch pipe are two or three times smaller than the width of the slots. Consequently, the desired fineness of the milling can be obtained by changing the rotational velocity of the disk with blades and the clearance between the rods.

---

Belarusian State Technological University, 13A Sverdlov Str., Minsk, 220050; email: alex\_levdansky@mail.ru. Translated from *Inzhenerno-Fizicheskii Zhurnal*, Vol. 77, No. 5, pp. 46–51, September–October, 2004. Original article submitted October 29, 2003; revision submitted December 30, 2003.

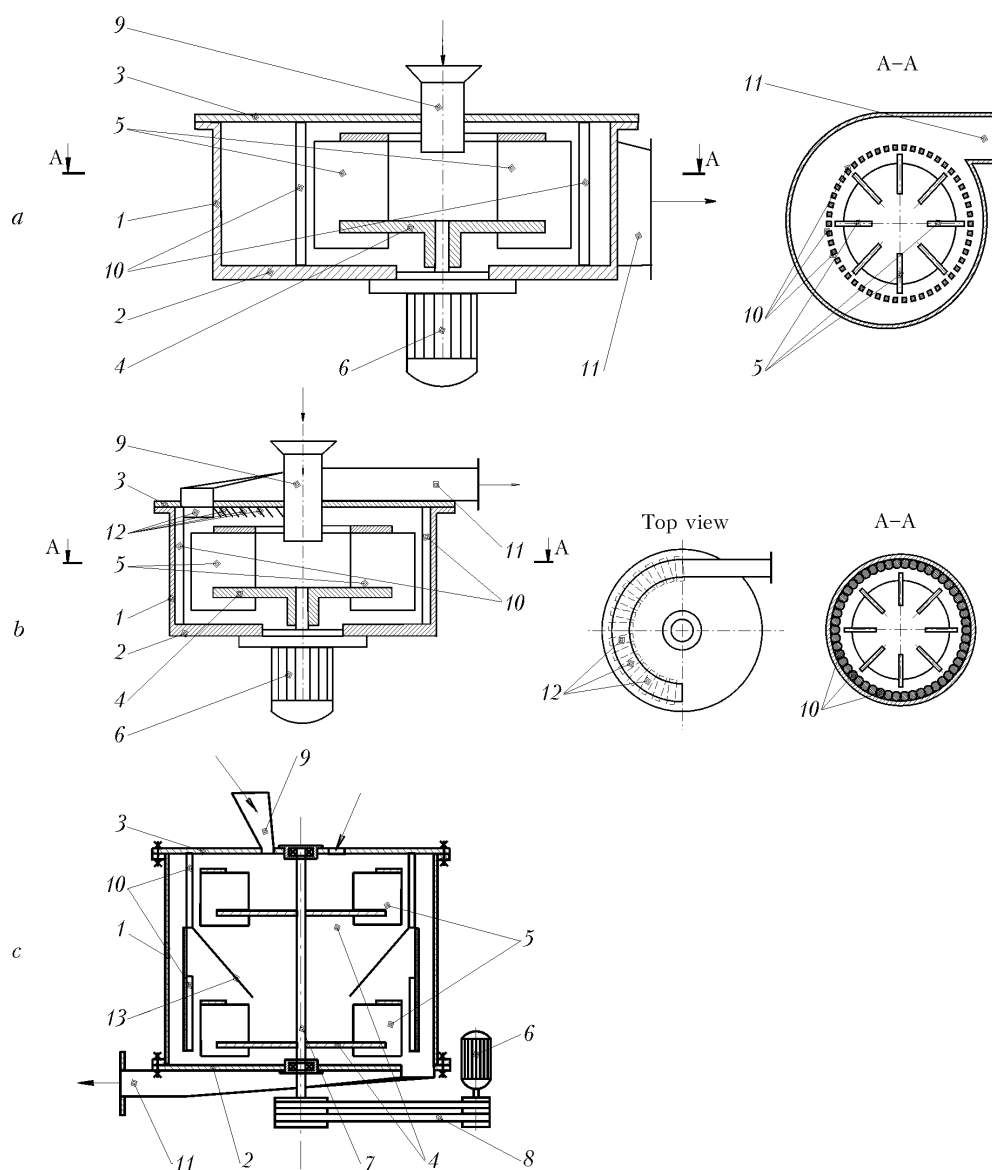

Fig. 1. Centrifugal impact mills with removal of the material milled through a tangential branch pipe (a) and through the top (b) and two-stage mill with removal of the material milled through the bottom (c): 1) body, 2) bottom, 3) cover, 4) disk, 5) blades, 6) electric motor, 7) shaft, 8) V-belt transmission, 9) inlet branch pipe, 10) reflecting rods, 11) outlet branch pipe, 12) bumper plates, 13) cone.

In mill *b*, reflecting rods of round cross section are installed immediately adjacent to each other. Here, the rising air flow carries the milling products through the ring window of the cover to the spiral-like channel and then, through outlet branch pipe 11, to the cyclone and filter for separation. Bumper plates 12, installed in front of the ring window of the cover at an angle to the direction of rotation of the rotor, form a flow-through classifier. The flow of gas-carrying solid particles, which rises from the milling zone, becomes zigzag-like when passed through the clearance between the plates of the classifier. In this case, large particles having a higher inertia strike against the inclined plates, bounce back from them, fall down on the blades, and are milled once again. Small particles having a lower inertia are carried by the air flow through the clearances and are removed from the mill. This mill can be used for milling of hard materials since in it the material milled is subjected to repeated impact.

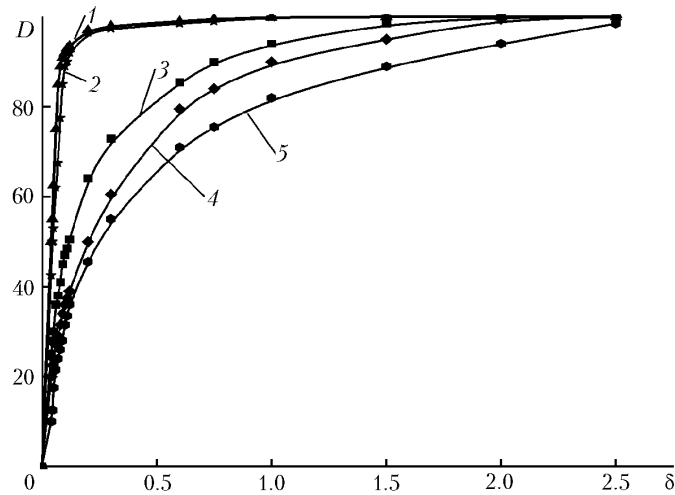

Fig. 2. Fractional composition of the products of impact milling of various materials: 1) lime (granules of size 4–8 mm), 2) chalk (particles of size 4–8 mm), 3) gypsum stone, 4) sylvinite (particles of size 3–10 mm), 5) grain (barley).  $\delta$ , mm;  $D$ , %.

The third mill (variant *c*) is a two-stage mill in which two disks with blades are installed on a common shaft. In such a mill, a material is initially milled at the first milling stage and then undermilled large particles are milled at the second stage. The first milling stage corresponds in design to mill *a* and the second stage corresponds to mill *b*. In mill *c*, the material is not accumulated in the milling zone; it passes through the two stages and is carried through the ring window in the bottom and the tangential branch pipe to the cyclone. Such a mill can effectively mill a material of medium hardness.

The main criteria of the efficiency of milling in any mill is the specific energy consumption and the quality of the product obtained. The energy consumption is usually estimated by the ratio between the energy expended for milling of a material and the amount of this material (kW·h/ton). The best qualitative characteristic of the product obtained is its granulometric (fractional) composition (particle-size distribution).

The energy expended for milling and the quality of the milling depend on the parameters of the process and the characteristics of the material milled. The parameters of the impact milling are the rate and angle of impact, the number of impacts, the specific load on the material, the geometric sizes of the units and members of the mill, etc. The characteristics of the material milled are its geometric sizes, physicochemical parameters (hardness, modulus of elasticity, ultimate strength), humidity, etc. It is practically impossible to take into account the effect of all the parameters of the milling process and the characteristics of the initial material in a theoretical model of impact milling; therefore, the efficiency of milling in the mills considered was determined experimentally. Initially we estimated the degree of single-impact milling of a material in a mill. The investigations were carried out with a mill of design presented in Fig. 1b, in which reflecting rods 10 of circular or rectangular cross section were installed immediately adjacent to each other (without a clearance). To exclude the repeated milling, the milled material was removed not through the cover but through the ring window and the tangential branch pipe in the bottom, as in the mill presented in Fig. 1c. The rotor in the mill used was 400 mm in diameter at the ends of the blades and had a rotational velocity of 750–2900 rpm.

The results of single-impact milling of various materials are presented in Figs. 2–4 in the form of distribution functions, where the particle size  $\delta$  is plotted on the abscissa and the quantity  $D$  (in percent), equal to the ratio between the mass of particles whose diameter is smaller than  $\delta$  and the total mass of the milling product, is plotted on the ordinate axis. The fractional distributions of the products of impact milling of the materials studied (see Fig. 2) were obtained at a rotational velocity of the rotor of 2900 rpm. The barley had a humidity of 13% and the humidity of other materials was 2–3%. In all the experiments, the rate of milling of a material was 460–520 kg/h and the size of the initial particles was 4–8 mm. It is seen from the figure that the lime granules and chalk particles are milled most finely in the process of single-impact milling and, as the examination of the milling products under a microscope

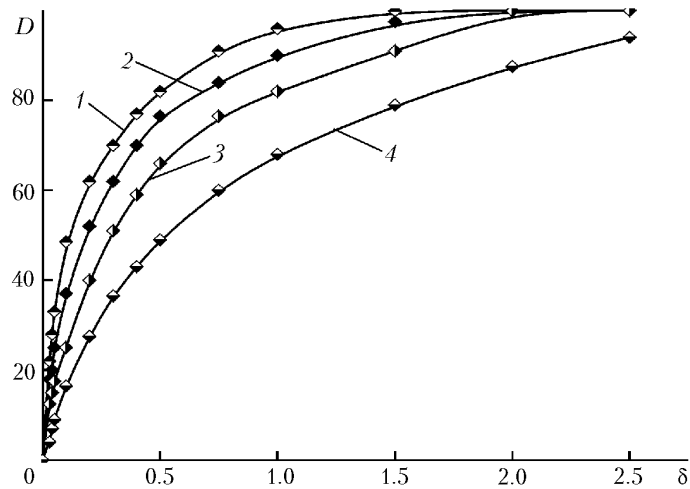

Fig. 3. Fractional composition of the products of impact milling of sylvinitite at an output of 0.061 (1), 0.133 (2), 0.211 (3), 0.333 kg/sec (4).  $\delta$ , mm;  $D$ , %.

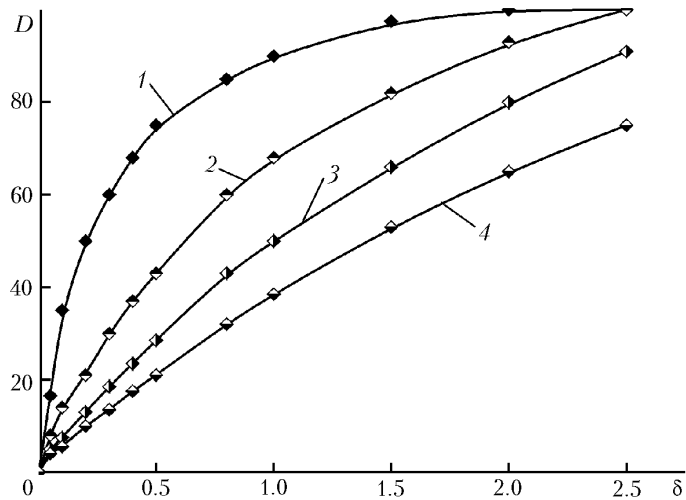

Fig. 4. Fractional composition of the products of milling of sylvinitite at a rotational velocity of the rotor of  $w = 62.8$  (1), 33 (2), 21 (3), and 16 m/sec (4).  $\delta$ , mm;  $D$ , %.

has shown, they practically break down into small crystals. The grain and, first of all, its elastic shell are milled substantially worse.

Figures 3 and 4 show the results of milling of sylvinitite. The dependence of the fractional composition of the milling products on the load of the initial material changed from 0.061 to 0.333 kg/sec, is presented in Fig. 3, and the dependence of the fractional composition of the milling products on the rotational velocities of the rotor, changed from 750–3000 rpm, is presented in Fig. 4.

Mathematical processing of the experimental data with the use of the Rosin–Rammler formula allowed us to obtain an expression for the fractional composition of the products of single impact milling of a material in the centrifugal impact mills presented in Fig. 1:

$$D = 100 \left[ 1 - \exp \left( -0.68 \left( \frac{\delta}{\delta_{50}} \right)^{0.75} \right) \right]. \quad (1)$$

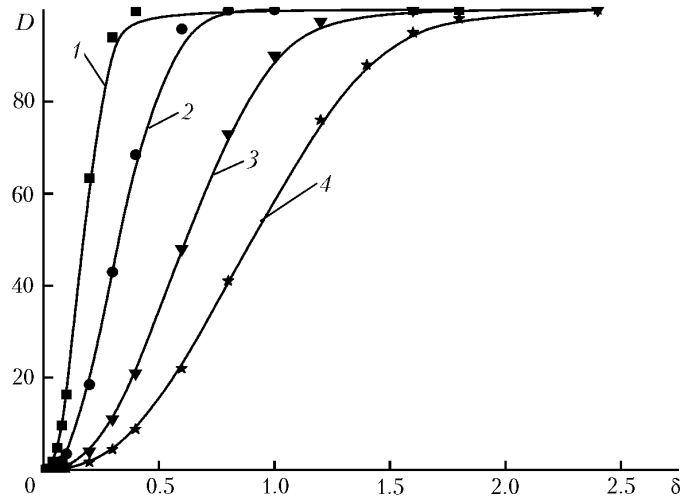

Fig. 5. Fractional composition of the products of milling of sylvinitite in the mill shown in Fig. 1a at a slot size of  $b = 0.5$  (1), 1 (2), 2 (3), and 3 mm (4).  $\delta$ , mm;  $D$ , %.

We have also obtained an empirical dependence of the particle size  $\delta_{50}$  on the characteristics of the material milled, the load on this material, and the circumferential rotational velocity of the rotor at the ends of the blades:

$$\delta_{50} = 2.71cw^{-1.42}G. \quad (2)$$

Examination of the largest particles in the milling products has shown that their size is 2.5–3 times smaller than the size of the particles in the initial material even in the case of milling of grain or gypsum stone. It has been established that the shape of the rods (with a circular or a rectangular cross section) has no significant influence on the fractional composition of the milling products. The process of milling with simultaneous classification of the milling product was investigated in mill *a*. In this case, the reflecting rods had a square cross section ( $14 \times 14$  mm) and the distance between them was changed from 0.5 to 4 mm. Initially we investigated the milling of sylvinitite and then the milling of other materials at a rotational velocity of the rotor of 2300 and 1450 rpm and a load on the material of 0.133 kg/sec. In the course of experiments we continuously determined the fractional composition of the milling product passed through the slots between the rods. The experiments the results of which are presented in Fig. 5 have shown that the fractional composition of the milling product is mainly determined by the size of the slots between the rods. In all the experiments conducted with different materials, the maximum size of the particles that passed through the slots between the rods was

$$\delta_{\max} = (0.5 - 0.75) b. \quad (3)$$

The fractional composition of the milling product that passed through the slots between the reflecting rods can be also determined, with an accuracy sufficient for engineering calculations, by the Rosin–Rammler formula:

$$D = 100 [1 - \exp(-45.38b^{-2.3}\delta^{2.5})]. \quad (4)$$

In all the experiments, we measured the energy expended for drive of the mill. Figure 6 presents the dependences of the energy expended for milling of various materials on the load on them at a rotational velocity of the rotor of 3000 rpm. It is seen from these dependences that, even in the idle running regime, the electric energy consumption by a mill ranges from 1.8 to 3 kW depending on the rotational velocity of the rotor. A major portion of this energy is expended for operation of the mill as a fan. Curves 1–3 were obtained for mill *a* in which continuous flow-through classification is realized with the use of reflecting rods installed at a distance of 1 mm from each other. In the case of milling of line (curve 1), its granules are milled by impact into small crystals with sizes smaller than 0.5 mm (which

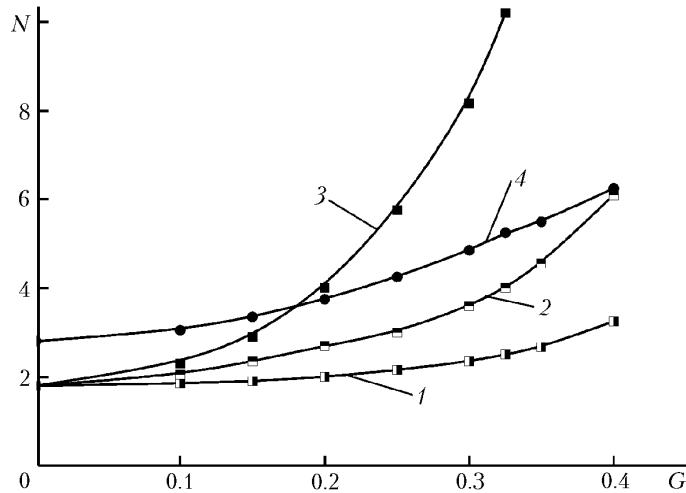

Fig. 6. Dependence of the energy consumption on the load on the material milled: 1–3) for the mill shown in Fig. 1a (1) lime, 2) gypsum stone, 3) barley grain); 4) for the mill shown in Fig. 1c (barley grain).  $G$ , kg/sec;  $N$ , kW.

is clearly seen from Fig. 2), which are easily carried by the air flow through the slots between the rods and are not accumulated in the milling zone; therefore, the energy is expended only for acceleration of particles. Curves 2 and 3 were obtained in the process of milling of gypsum stone and grain in this mill. These materials are not milled by impact into particles of size smaller than 0.5 mm and therefore are accumulated in the milling zone. In this case, particles are additionally milled as a result of their abrasion in this zone, which leads to additional energy losses, especially at high loads on the mill.

Consequently, the mills presented in Fig. 1a and b can be used for milling of such dry materials as lime, chalk, clay clods, and granules and crystals of salts. At low loads, lower than 200 kg/h, and a rotor diameter of 400 mm, these mills can be used for milling of harder and more difficultly milled materials. For example, several mills of variant *b* have been used for a long time for milling of roots and grasses in the production of medicines and food additions. Curve 4 (see Fig. 6) indicates that a higher energy is expended for milling of barley grains in mill *c*. In this mill there are no accumulation zones and a material is milled by impact in two stages; therefore, the energy consumption increases smoothly with increase in the load on the material milled. The quality of milling of fodder grain in such a mill is much better than in the hammer breakers used at present, and the relative electric energy consumption of this mill is 20–30% smaller. For example, if the grain milled by a hammer breaker contains as much as 1% of whole grains and 15% of one-halves of grains, the largest size of particles in the grain milled in mill *c* is 1.2 mm. Therefore, it is possible that in the near future such mills will take the place of hammer mills in the milling of fodder grain.

## NOTATION

$b$ , width of the slots between the rods, m;  $c$ , coefficient allowing for the physical-mechanical properties of the material and the size of its initial particles ( $c = 0.05$  for lime and chalk,  $c = 0.12$  for gypsum stone,  $c = 0.2$  for sylvinit,  $c = 0.25$  for grain);  $D$ , ratio between the mass of the particles whose size is smaller than  $\delta$  and the total mass of the milled particles, %;  $G$ , amount of material loaded to the mill, kg/sec;  $N$ , energy consumption, kW;  $w$ , circumferential velocity of the rotor at the ends of the blades, m/sec;  $\delta$ , size of the material particles, m;  $\delta_{50}$ , particle size at which the mass of the smaller-size particles accounts for 50%.

## REFERENCES

1. V. I. Revnivitsev, G. V. Gaponov, L. P. Zarogatskii, et al., in: *Selective Destruction of Minerals* [in Russian], Nedra, Moscow (1988), pp. 135–162.

2. S. E. Andreev, V. A. Perov, and V. V. Zverevich, in: *Crushing, Size Reduction, and Screening of Mineral Resources* [in Russian], Nedra, Moscow (1980), pp. 110–134.
3. P. M. Sidenko, in: *Size Reduction in the Chemical Industry* [in Russian], Khimiya, Moscow (1977), pp. 26–40.
4. A. E. Levdanskii, A. A. Garabazhiu, and E. I. Levdanskii, *Mill* [in Russian], Pat. RB No. 4707 B 02 C 13/14.
5. A. E. Levdanskii, V. S. Volod'ko, and E. I. Levdanskii, *Centrifugal Mill*, [in Russian], Pat. RB No. 3011 B 02 C 13/08.
6. A. E. Levdanskii, A. I. Vil'kotskii, and E. I. Levdanskii, *Mill* [in Russian], Pat. RB No. 4706 B 02 C 13/14.